

# KENDAL E

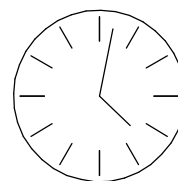

130 min

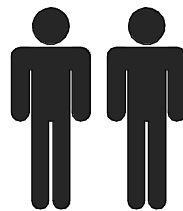

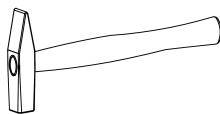
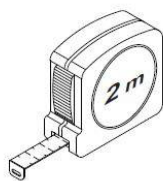
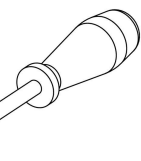
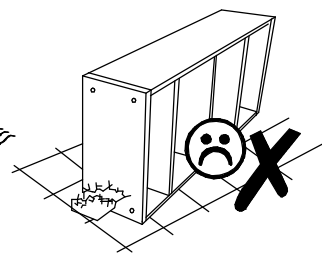
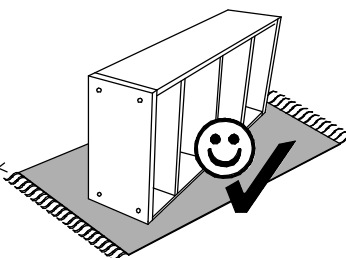
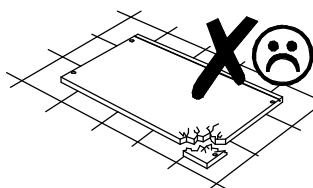
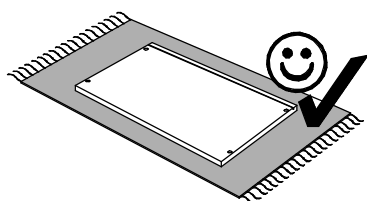
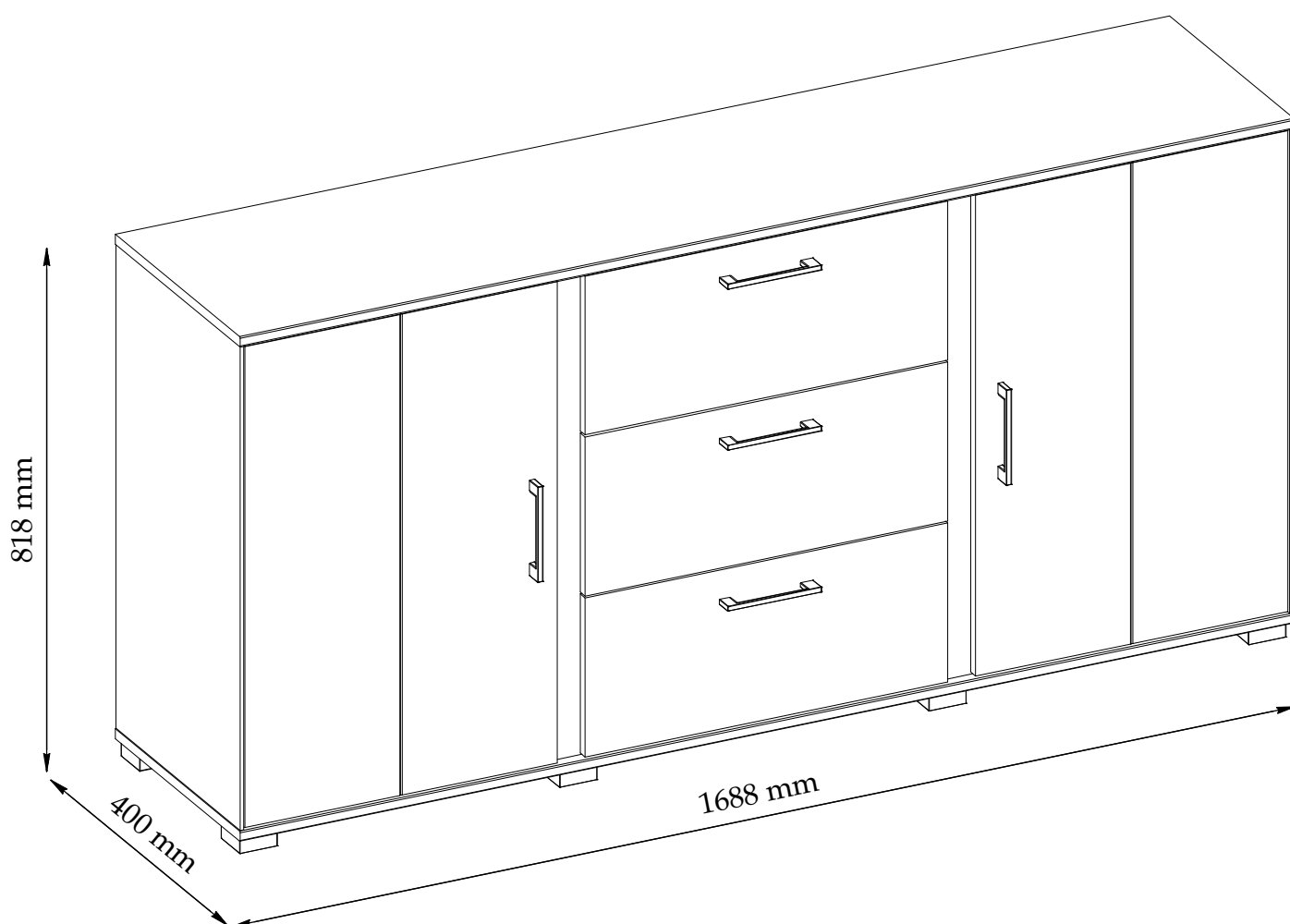
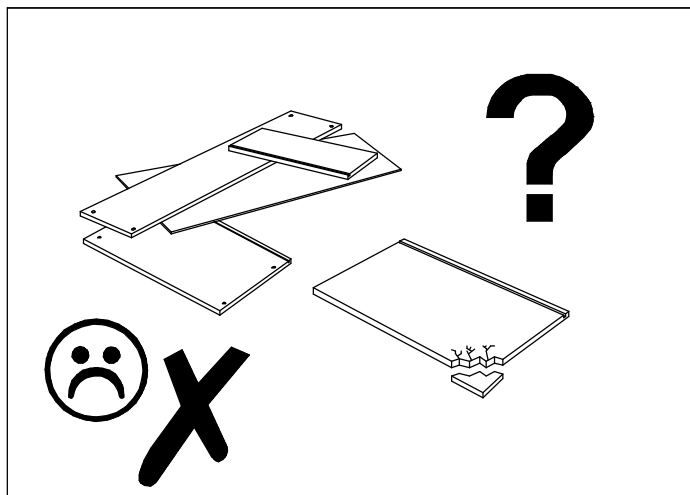
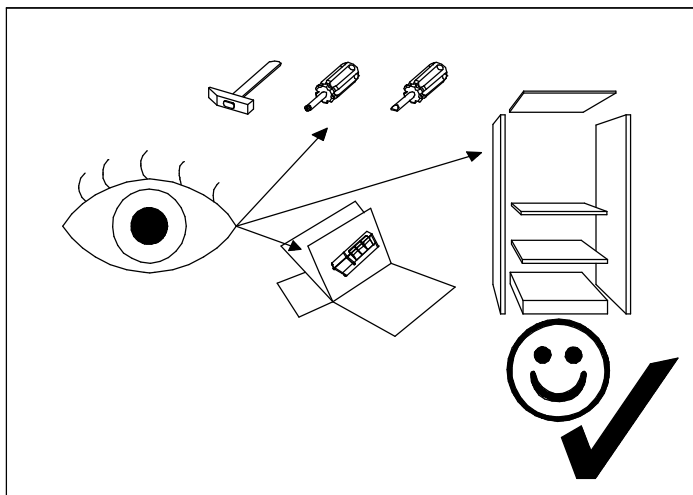
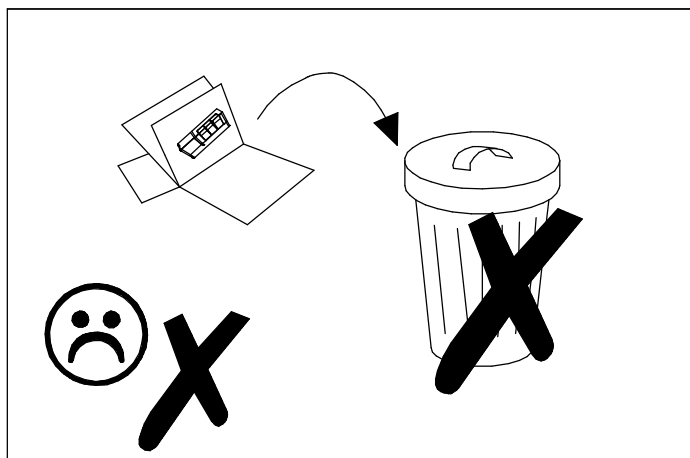
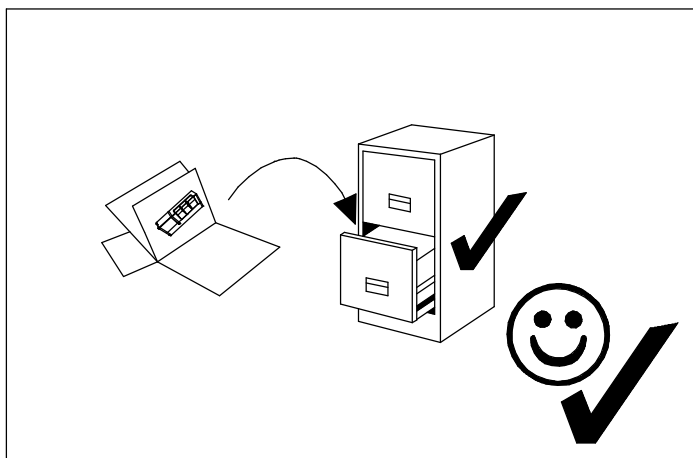
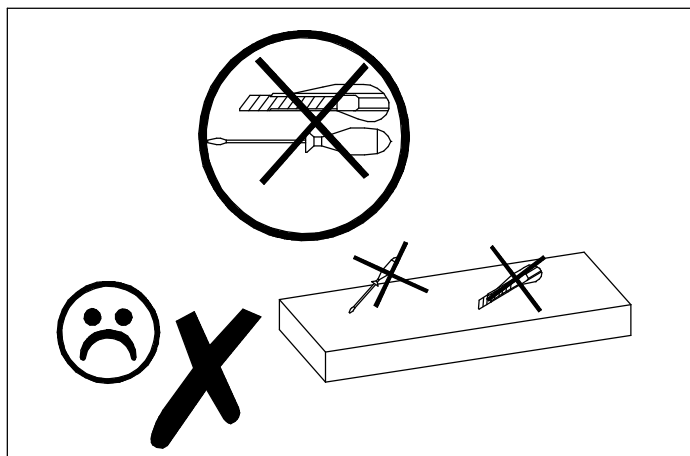
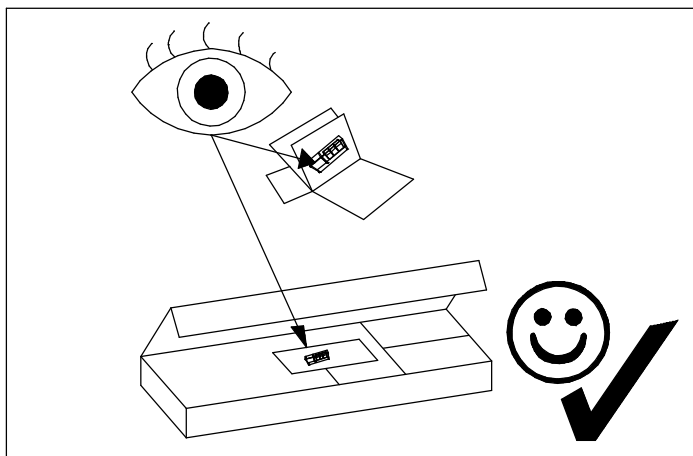

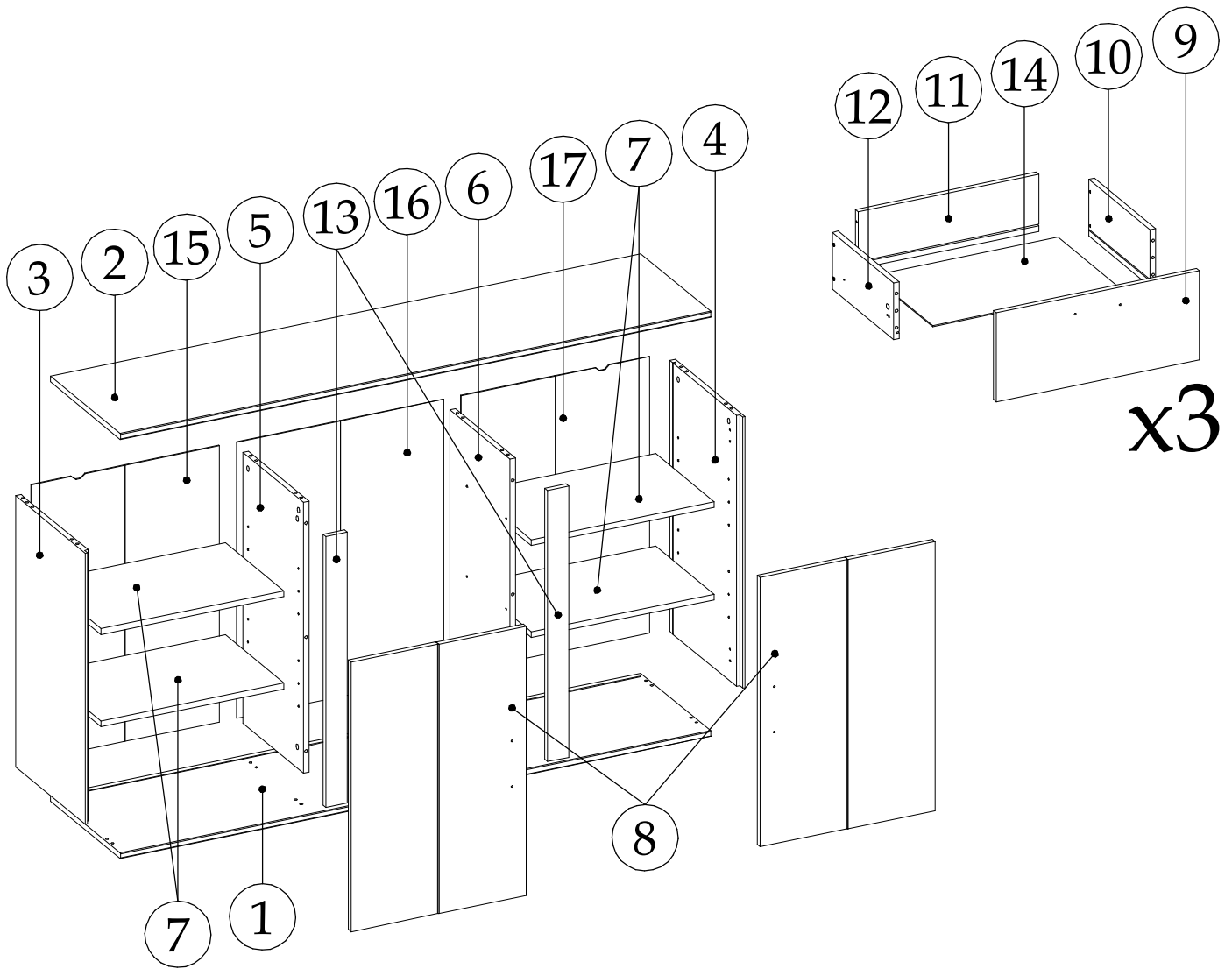
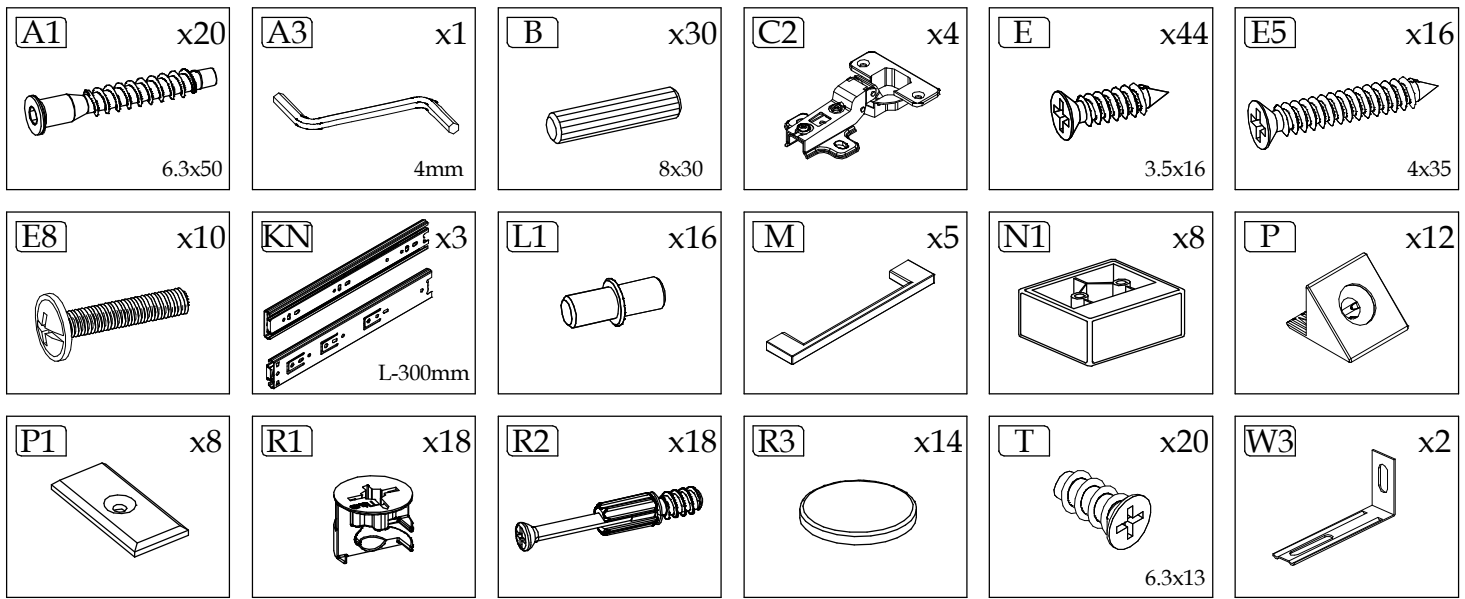

Element symbol	Measurements				Code	Paket
1	1688	400	16	1	1002	1/2
2	1688	400	16	1	1003	1/2
3	761	397	16	1	1004	1/2
4	761	397	16	1	1005	1/2
5	761	344	16	1	1001	1/2

6	761	344	16	1	1007	1/2
7	523	334	16	4		2/2
8	756	500	16	2	3030	2/2
9	580	250	16	3	1010	2/2
10	350	160	16	3	1011	2/2
11	517.5	160	16	3	1012	1/2 2/2

12	350	160	16	3	1013	1/2
13	761	60	16	2	1027	1/2
14	531.5	346	3	3		1/2
15	775	538	3	1	1034	1/2
16	775	591	3	1		1/2
17	775	538	3	1	1034	1/2

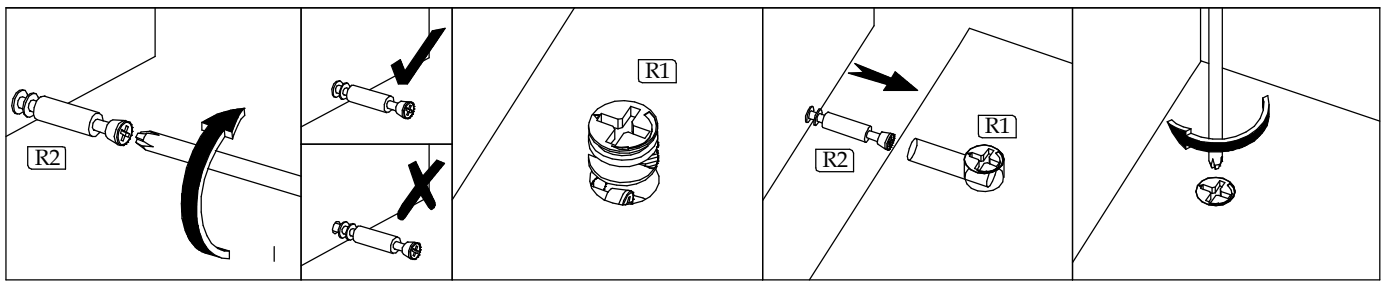

▶ 1

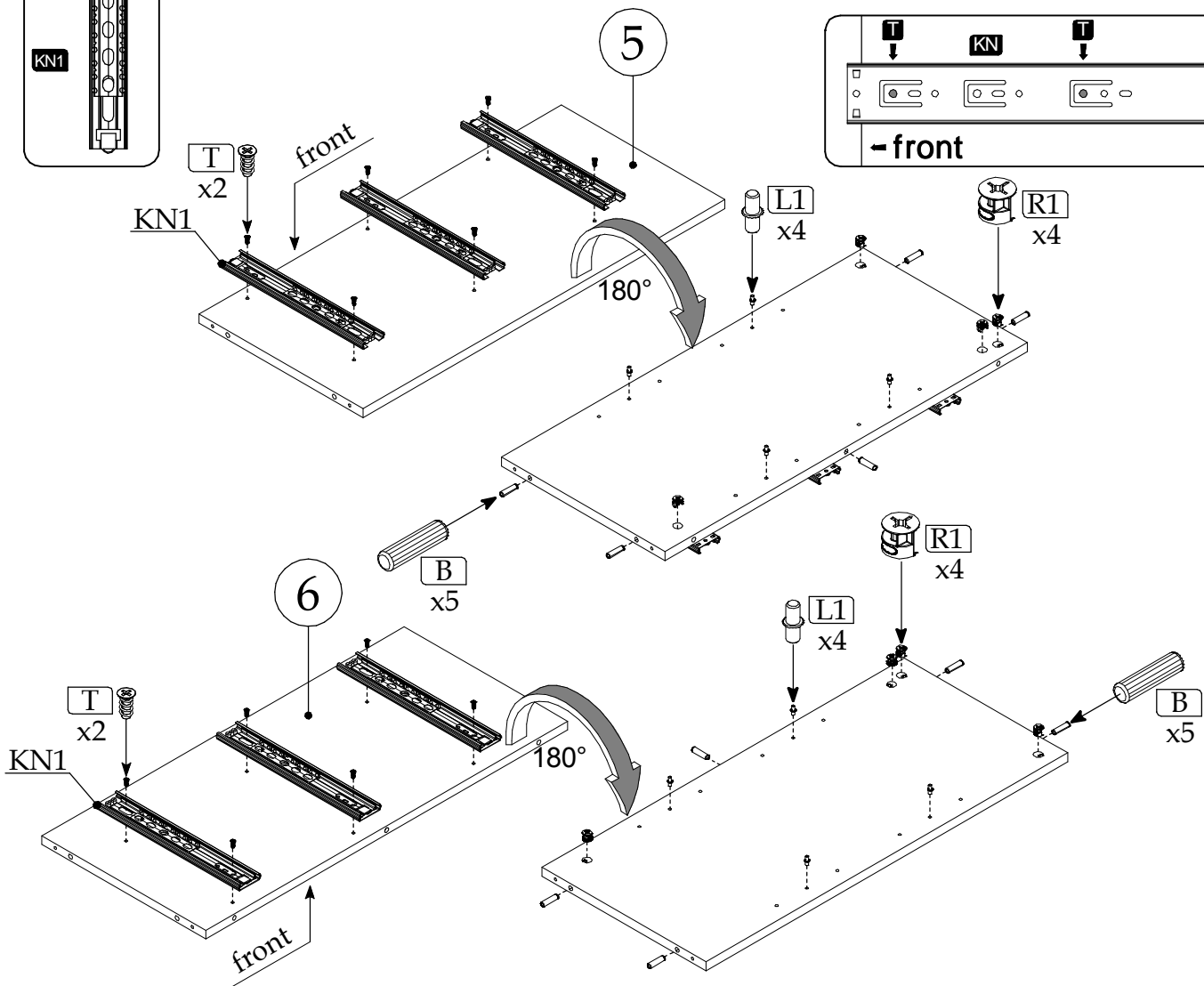
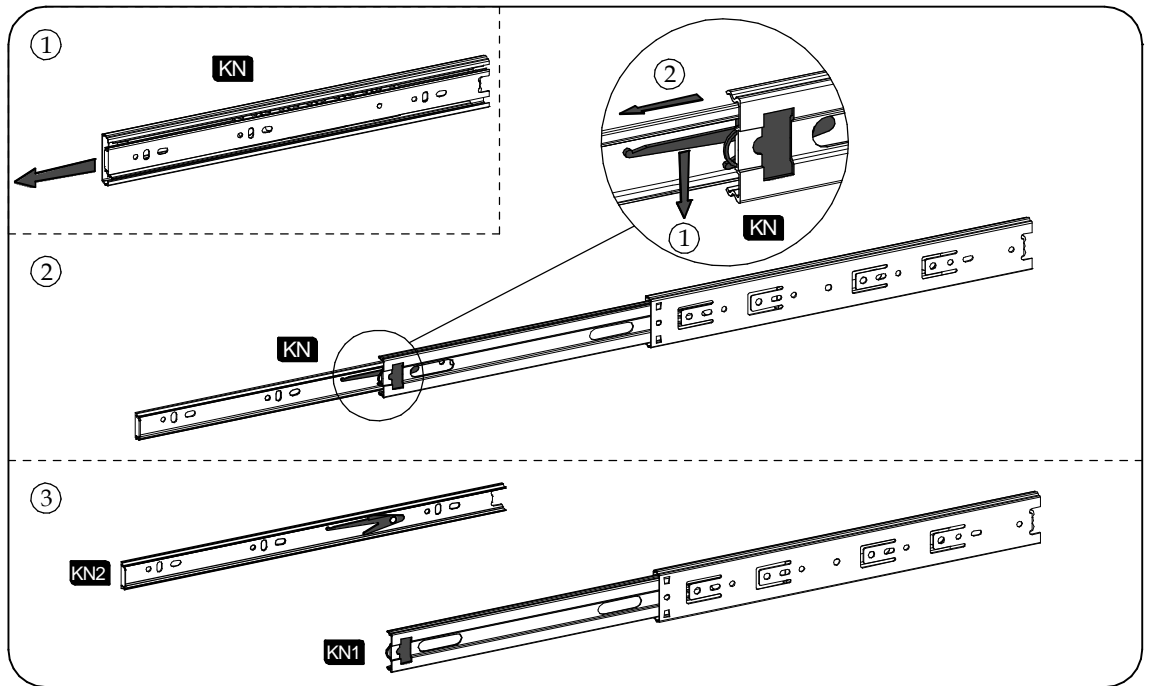
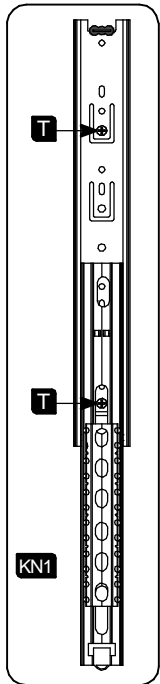

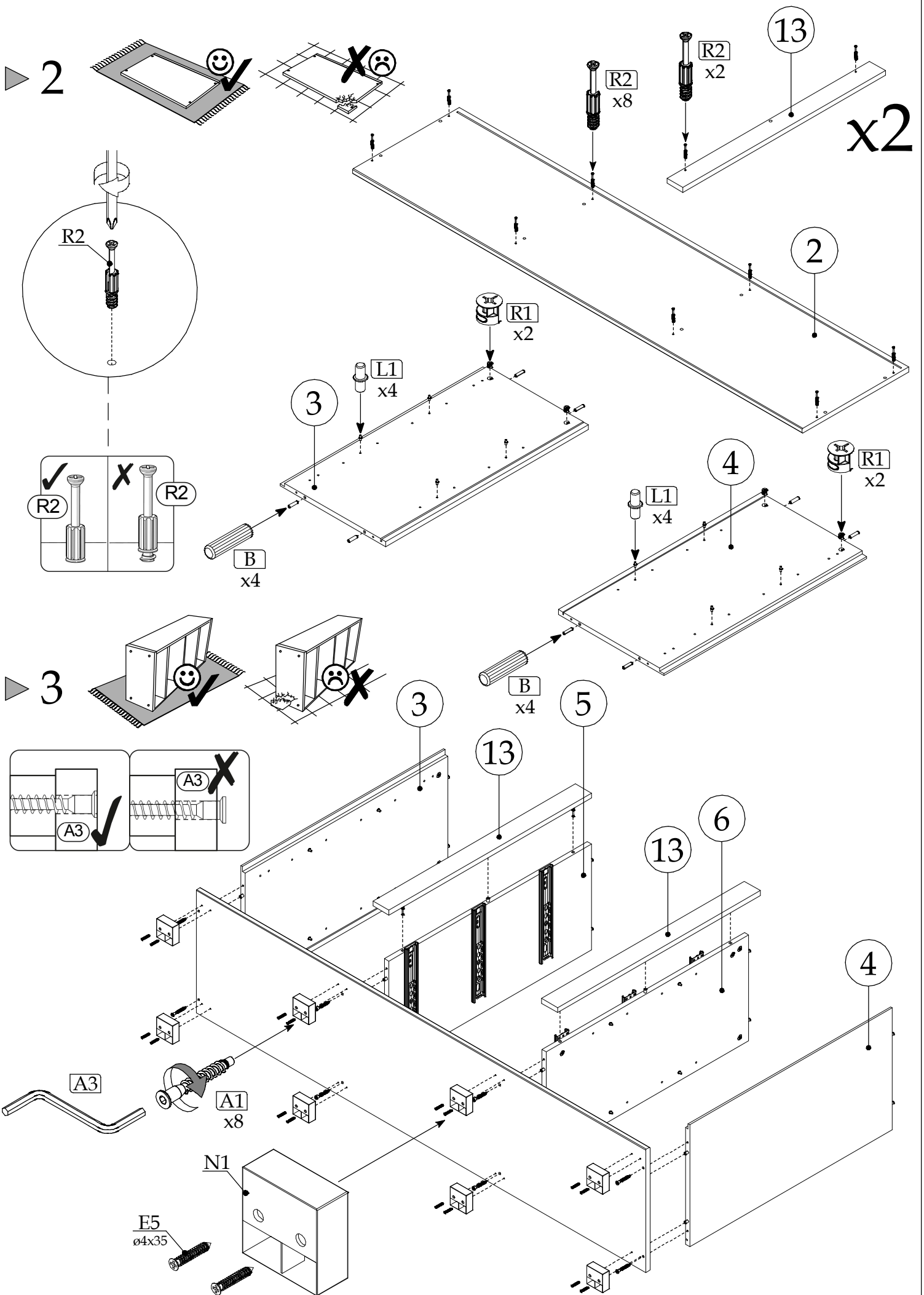

▶ 4

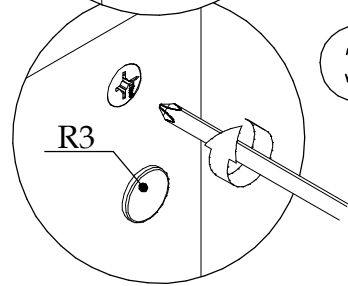
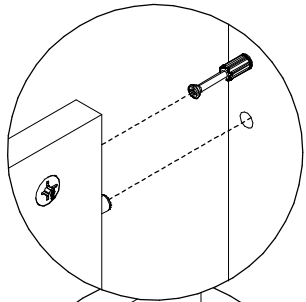

3

1

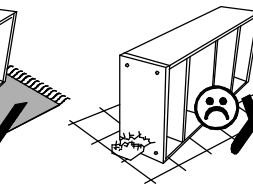
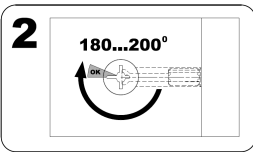

▶ 5

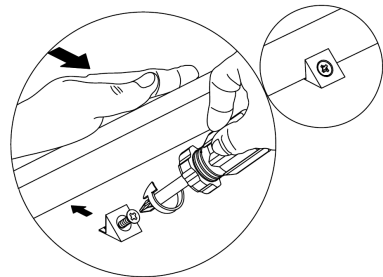
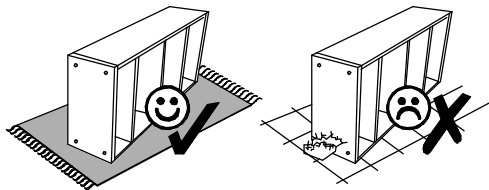

15

5

6

2

16

17

4

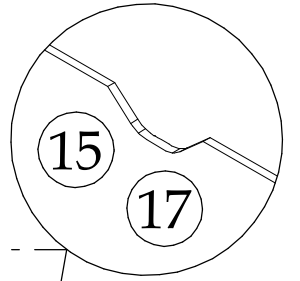

A

B

E  
ø3.5x16

P  
x12

E  
ø3.5x16

P1  
x8

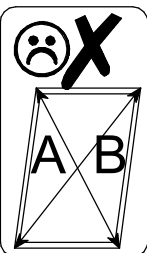
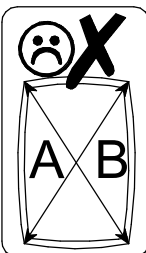
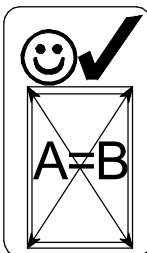

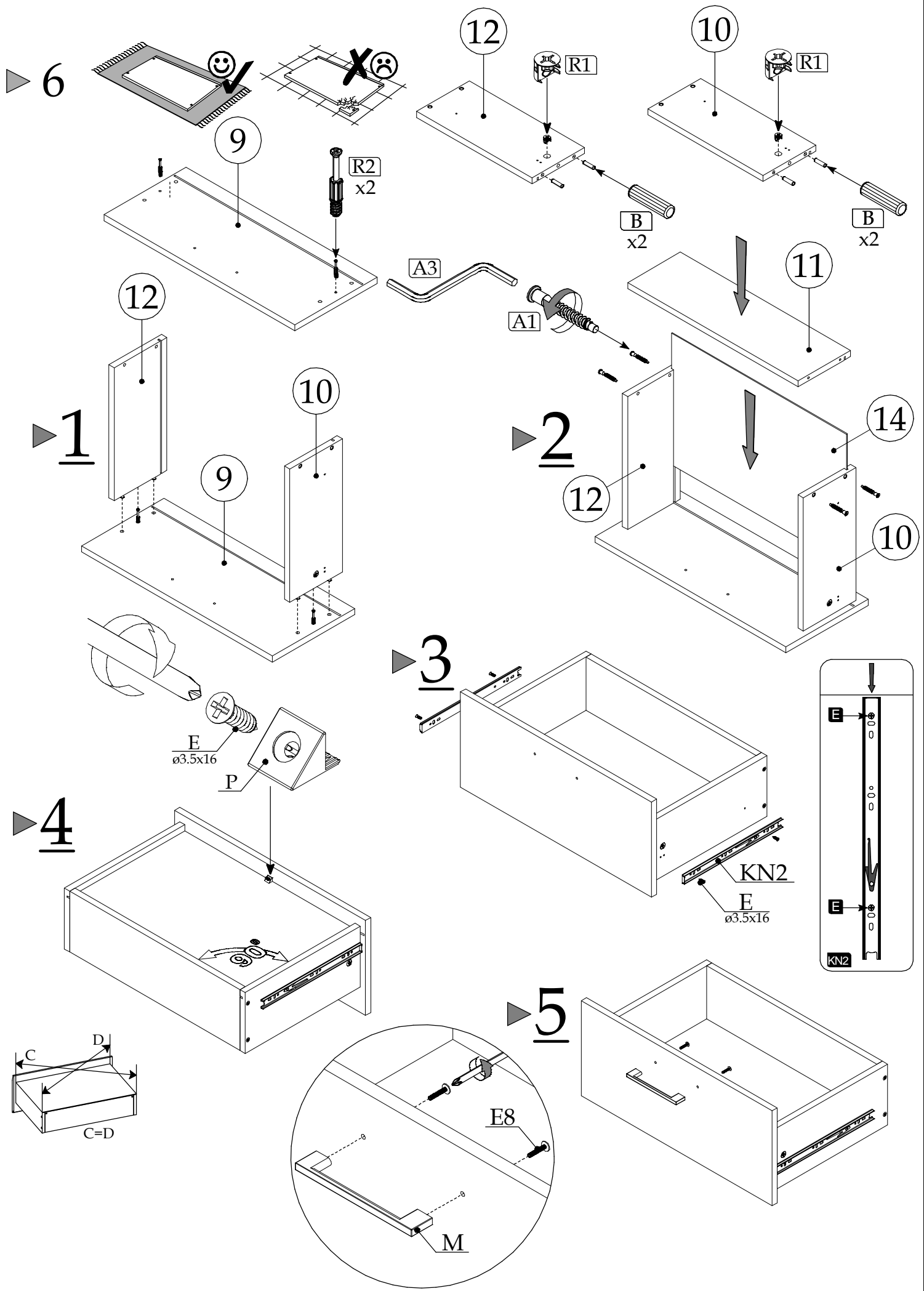

▶ 7

max. 3kg

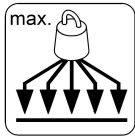

max  
20 kg

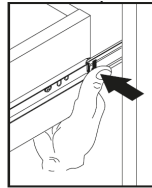
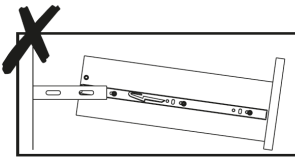
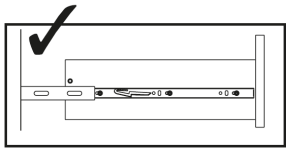
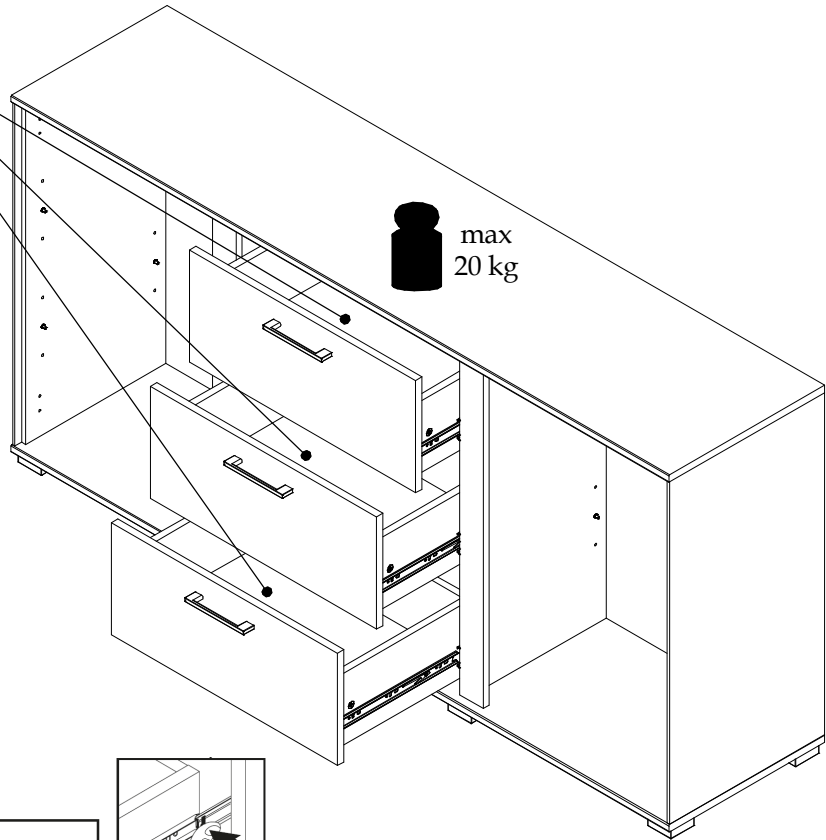

▶ 8

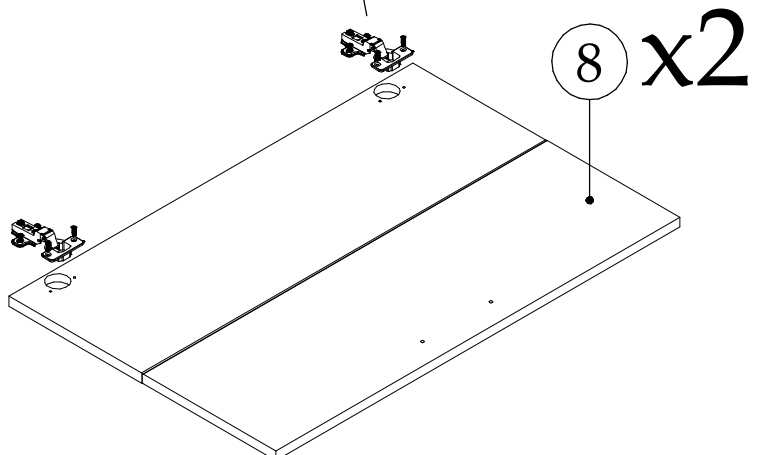
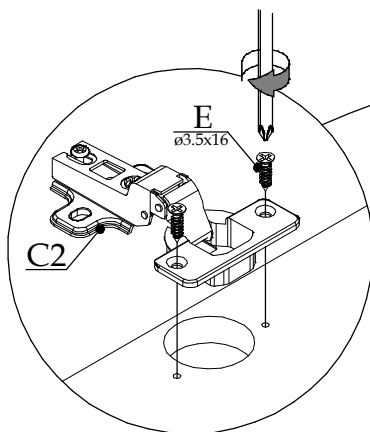
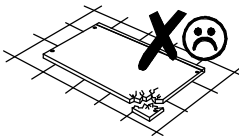
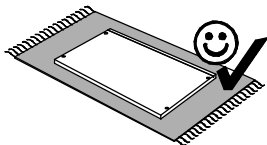



▶ 9

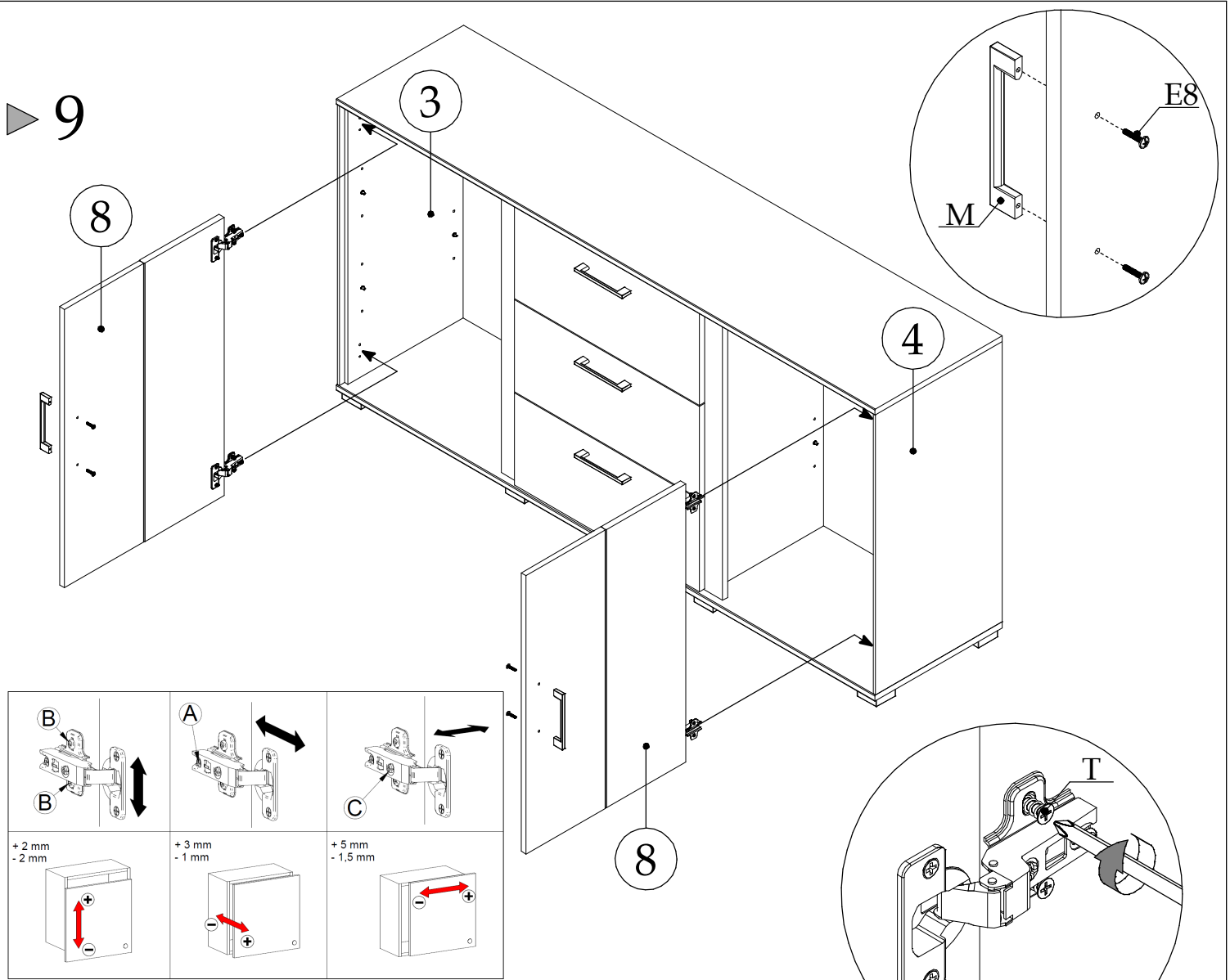

▶ 10

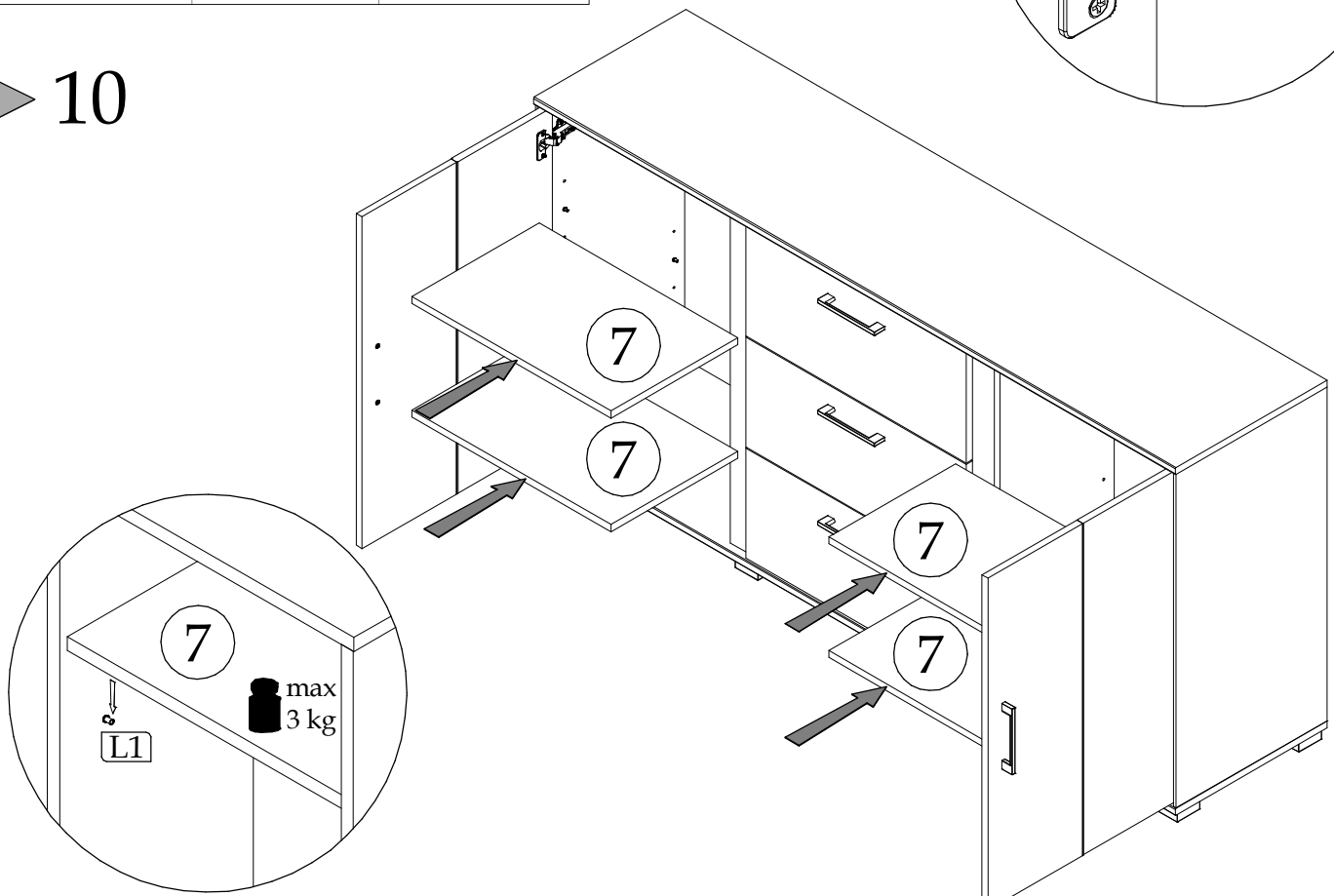

▶ 11

